

NiCd Battery pack 1.8 – 4.5 Ah

Nickel-cadmium cells (NiCd)

Product description

- High-temperature NiCd battery pack for use with emergency lighting units
- 4-year design life
- 1-year guarantee from delivery date (conditions at www.tridonic.com)

Properties

- Constant high-temperature operation
- Temperature depending on the used emergency lighting unit (refer to respective emergency control gear data sheet)
- Good charging properties at high temperature
- High energy maintenance of the charged battery
- Certified quality manufacturer
- Casing material made of polycarbonate
- 1.0 m integrated double-insulated cable
- 1.0 mm² solid wire
- Suitable for emergency lighting equipment as per IEC 60598-2-22



Standards, page 4



Fig. 1



Fig. 2



Fig. 3

NiCd Battery pack 1.8 – 4.5 Ah

Nickel-cadmium cells (NiCd)

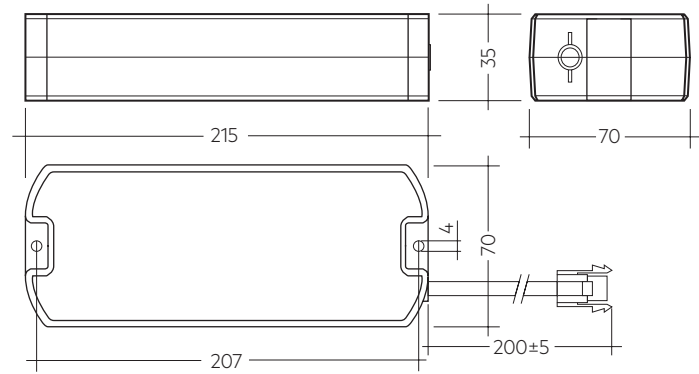

Fig. 1

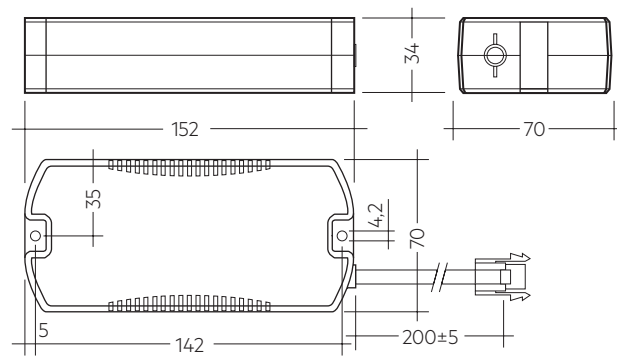

Fig. 2

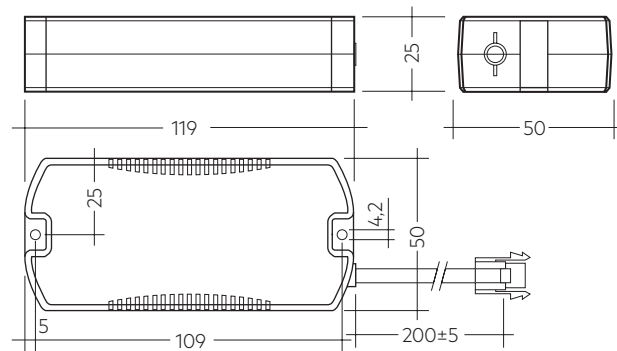

Fig. 3

Technical data

Battery voltage per cell	1.2 V
Max. battery casing temp. tc (design life of 4 years)	45 °C
Ambient temperature range	+5 ... +40 °C

Ordering data

Type	Article number	Packaging, carton	Packaging, outer box	Weight per pc.
Battery pack 1.8 Ah with plug				
Pack-NiCd 3C CON	28001221	5 pc(s).	10 pc(s).	0.200 kg
Pack-NiCd 4C CON	28001222	5 pc(s).	10 pc(s).	0.250 kg
Battery pack 4.5 Ah with plug				
Pack-NiCd 3D CON	89800389	5 pc(s).	10 pc(s).	0.534 kg
Pack-NiCd 4D CON	89800390	5 pc(s).	10 pc(s).	0.661 kg
Pack-NiCd 5D CON	28001181	5 pc(s).	10 pc(s).	0.840 kg
Pack-NiCd 6D CON	89800391	5 pc(s).	10 pc(s).	0.990 kg

Spezific technical data

Type	Article number	Figure	Number of cells	Capacity	Dimensions L x W x H
Battery pack 1.8 Ah with connector					
Pack-NiCd 3C CON	28001221	3	3	1.8 Ah	119 x 50 x 25 mm
Pack-NiCd 4C CON	28001222	3	4	1.8 Ah	119 x 50 x 25 mm
Battery pack 4.5 Ah with connector					
Pack-NiCd 3D CON	89800389	2	3	4.5 Ah	152 x 70 x 34 mm
Pack-NiCd 4D CON	89800390	2	4	4.5 Ah	152 x 70 x 34 mm
Pack-NiCd 5D CON	28001181	1	5	4.5 Ah	216 x 70 x 37 mm
Pack-NiCd 6D CON	89800391	1	6	4.5 Ah	216 x 70 x 37 mm

1. Standards

The battery cells are designed to comply with the IEC international standard and tested according to the normative permanent charge endurance test described in the IEC 61951-1 standard. This performance is mandatory for use in Emergency Lighting Units to comply with the IEC 60598 2.22.

1.1 Glow-wire test

according to EN60598-1 with increased temperature of 850 °C passed (valid for housing and connectors).

2. Thermal data

2.1 Storage conditions

- Avoid atmosphere with corrosive gas
- Disconnect batteries before storage or delivery
- Avoid storage of discharged batteries
- Store batteries within the specified temperature range in low humidity conditions. Optimal storage conditions are:
 - relative humidity: < 65 %
 - temperature: -20 ... +25 °C for up to 6 months after printed date of manufacture. If the batteries are stored for longer than 6 months, it is recommended to recharge to 50% of the full capacity. After this the batteries can be stored for another 6 months. With this method, a maximum storage time of 12 months can be achieved.
 - temperature: -20 ... +20 °C for up to 12 months after printed date of manufacture
- A long term storage in open circuit leads to battery self discharge and deactivation of chemical components. It could be required to charge and discharge the batteries a few times to recover the initial performance.

3. Installation & commissioning

3.1 Activating NiCd batteries

When using rechargeable NiCd batteries for emergency lighting following point are essential in order to achieve the specified design life time of the batteries:

In order to activate new batteries, 2-3 full charging-discharging are needed to make sure batteries achieve their rated capacity. This activating process is defined by running 2-3 full charging (24 hrs) and discharging (1/2/3 hrs) cycles of the batteries. If the first duration test fails, please repeat the test once again after a 24 hour charging period.

3.2 Avoidance of excessive cycling

During building installations, in many cases, mains supply is not available on a permanent 24-hour basis which then leads to unwanted, uncontrolled excessive battery cycles. This has a very strong effect on the design life time of the battery. Make sure that in such situations, the battery remains disconnected in the luminaire till the mains power supply is stable on a 24-hour basis.

It is strongly recommended to refer to the datasheets of Tridonic emergency control gears to avoid excessive cycling. At the same time, make sure that this information is handed over to the installation staff / electrician in order to ensure a proper way of installation and commissioning.

3.3 Avoidance of deep-discharge conditions

It is very important that NiCd batteries are not left connected for long periods in a discharged state. Following options may lead to a deep discharge situation and must be avoided:

- Storage periods of rechargeable batteries of over 6 month without recharging the battery packs.
- Shipment, storage of assembled emergency luminaires with battery pack connected to the emergency driver.

- Long periods of mains-interruptions of more than two weeks, once, the emergency system is installed and the battery pack is connected to the emergency driver.

4. Mechanical details

4.1 Battery leads

Pre-assembled length: 0.2 m double-insulated cable with plug connection
0.8 m double-insulated cable with plug and pre-stripped ends for connection with the emergency unit

Polarity: red (positiv +), black (negative -)

4.2 Emergency lighting unit end termination

9.0 mm stripped insulation

5. Technical data Accu

Capacity		
Rated minimum capacity	1.8 Ah	4.5 Ah
Typical weight per cell	45 g	124 g
Cell dimensions		
Diameter	22.5 mm	32.5 mm
Height	42.5 mm	60.5 mm

Consult individual emergency control gear data sheet for maximum allowable temperatures and allowed number of discharge cycles.

6. Safety

- Do not short-circuit the battery pack – when installing the luminaire make sure sharp edges do not come into contact with cables.
- Do not open or damage the battery pack or throw it into a fire.
- Protect the battery against moisture and keep away from water.
- Do not expose the battery to direct sunlight or excessive heat (See storage conditions).
- Transport and store the battery only in its original packaging.
- Comply with the transport conditions of the transport company.
- Follow the instructions on the safety data sheets.



Damage/improper use

If the battery is damaged or user incorrectly vapours and liquids may escape from it. If you come into contact with battery fluid wash immediate with water and seek medical assistance if necessary.

7. Disposal

- Do not dispose of batteries with normal waste.
- Comply with local regulations when disposing of batteries.

8. Miscellaneous

8.1 Additional information

Additional technical information at www.tridonic.com → Technical Data

Lifetime declarations are informative and represent no warranty claim. No warranty if battery pack was opened.