

# Power Unit: Single Channel

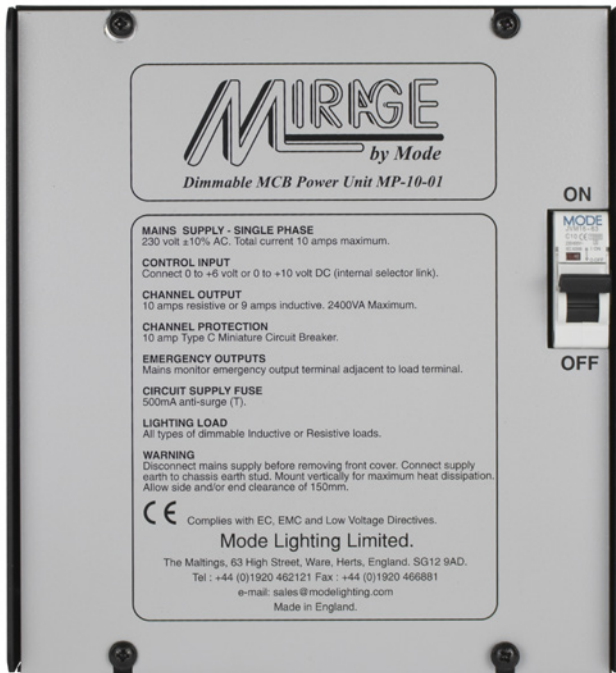

The Mirage MP-10-01 is a wall mounting, single channel, Dimmable Power Unit designed for the reliable leading edge, mains dimming of resistive or inductive lighting loads.

It is rated at 10 Amps (9 Amps inductive) and is protected by a Type C Miniature Circuit Breaker (MCB).

The control input could be either 0-6 Volt or 0-10 Volt from the Mode control systems or 1-10 Volt sinking control from Building Management Systems. The MP-10-01 is mounted in a black aluminum case with a natural anodised silver front panel.

## Key Features

- » Single dimmable channels of 10 amps resistive or 9 amps inductive loads.
- » Up to 2A of compatible LED load (check with manufacturer for LED de-rating factor).
- » Leading Edge Dimming Technology.
- » Control input suitable for use with 0-6 Volt, 0-10 Volt and 1-10 Volt controllers.
- » Circuit protection 10 Amp Type C MCB.
- » Emergency output fixed live MCB protected output for maintained emergency supply.
- » LED channel monitor to indicate the operation of the output.
- » Supply input 230/240 Volt. 50-60 Hz. 40 Amp maximum (100-125 Volt option available).
- » Internal test switch to enable unit to be locally tested to full on.
- » Triac with screw fixings can be removed for servicing.
- » External supply low voltage D.C. for use with remote dimmers and ancillary equipment.
- » Conduit cable entries (four) 21mm diameter suitable for use with conduits and trunking.
- » Complies with EC, EMC and Low Voltage Directives (CE).
- » 2 year warranty.



### System Architecture

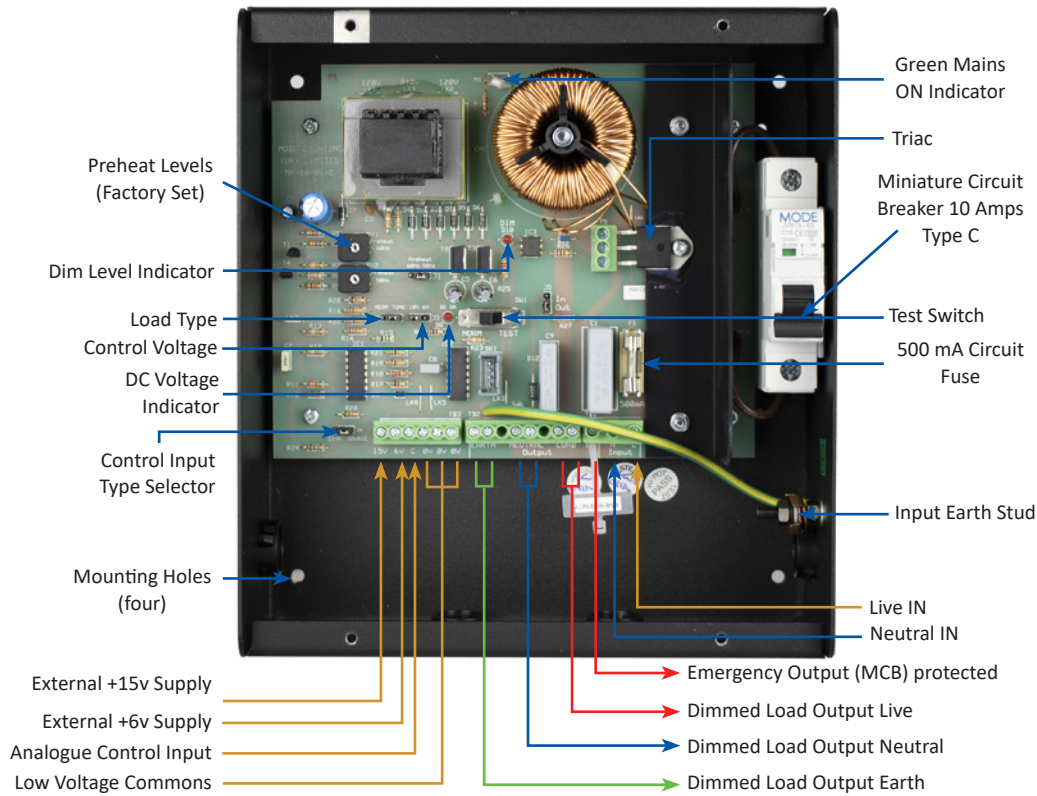

### Technical Data

Power	
Mains Supply	» 230/240 Volt, 50-60 Hz. 10 amp maximum.
Control Fuse	» 500 mA anti-surge (T).
Earth	» This product must be earthed.
Connections & Cable Specifications	
Channel Outputs	» Single channel of 10 amps resistive or 9 amps inductive loads. » Up to 2A for LED loads depending on LED de-rating factor.
Load MCB	» Individual Miniature Circuit Breaker (MCB) 10 amp Type C.
Control Input (i)	» 0-6 or 0-10 Volt D.C analogue control (selectable).
Control Input (ii)	» 1-10 Volt D.C. Sinking (selectable).
Mechanical	
Standards	» EMC Emissions EN55015, EMC Immunity EN61547, Harmonics EN61000-3-2, Voltage fluctuation EN61000-3-3, Safety EN60439-1 and EN60950.
Conduit Entries	» Four of 21 mm diameter.
Dimensions	» 220 mm x 200 mm x 75 mm.
Fixing Centres	» 182 mm x 178 mm.
Weight	» 1.35 kgs.
Packed Size	» 230 mm x 227 mm x 82 mm.
Packed Weight	» 1.5 kgs.



Mode Lighting Limited. The Maltings, 63 High Street, Ware, Hertfordshire, SG12 9AD. United Kingdom.  
 Tel: +44 (0) 1920 462121 | Fax: +44 (0) 1920 466881 | Email: sales@modellighting.com | www.modellighting.com